

LC-50 Installation Manual

Rev 9/22/08

The LC-50 is not approved for installation in certified aircraft.

Mechanical

The 1/4" diameter control Pot shafts may be trimmed to any desired length. Any 10K control pots may be substituted if desired. Knobs are not included with the kit, however, suggested part numbers and sources are on the last page of this manual.

Electrical

We suggest powering the LC-50 with your navigation light circuit switch and fuse via a 10 Amp CB or fuse.

The LC-50 is capable of dimming both incandescent and LED lighting. It is also capable of dimming devices that do not accept PWM and duty cycle variation to control brightness such as the GNS430W, certain audio panels, transponders and the Tru-Trak ADI. See list on the last page.

Refer to wiring plans on the following pages for your planned installation. It is acceptable to customize your system by mixing elements from the three diagrams. See suggestions for light Grouping and Channel Usage on Page 5.

When dimming multiple lamps with a single channel is important to have the lamps wired in parallel and not in series. See figure C on page 5 for an example of Parallel vs. Series wiring.

Cable for the dimmer controls is included. Use aircraft grade wire of the appropriate gauge for power, ground and output connections.

Configuration

Analog Outputs

Outputs "A01" and "A02" are provided to dim devices that do not accept PWM and duty cycle variation to control brightness. Please see a list of devices known to require analog dimming on the last page of this manual.

Only devices which do not dim normally on the outputs of "OUT1" – "OUT4" should be connected to the analog outputs. Do not use these outputs to dim Bulbs, LEDs, or EL lights as they have limited current carrying capability.

"A01" and "A02" are controlled by the potentiometers wired to "CH1" and "CH2" respectively. "A01" and "A02" outputs match outputs "OUT1" and "OUT2" respectively. They also are controlled by their respective channel's rate and offset adjustments.

Setting Rate and Offset

The LC-50 allows the user to set dimming rate and offset for each of the four channels. This is useful for combining outputs of multiple channels to be controlled by a single potentiometer. It is also useful to match the dimming rate of LEDs to other channels with incandescent bulbs.

1. Remove the cover of the LC-50.
2. Move the circuit board mounted switch to "SET". The red "SET" LED will illuminate.
3. For each channel:
 - a. Set the offset trimpot ("OFST1" – "OFST4") so the lamps energize at the desired main control potentiometer position. Clockwise rotation of the trimpot causes the channel to illuminate sooner.
 - b. Set the Rate trimpot ("RT1" – "RT4") to control the dimming rate of each channel. A red "SET" LED illuminates for each rate trimpot when the trimpot is in the neutral position. Clockwise rotation of the trimpot from the neutral position causes the channel to dim at a faster than normal rate. Counter-Clockwise rotation of the trimpot from the neutral position causes the channel to dim at a slower than normal rate.
4. After all eight trimpots are adjusted, move the switch to the "RUN" position. The "SET" LED will flash and the trimpot settings will be saved. Note that the trimpots have no effect unless the switch is in "SET" position.
5. Re-install the cover

Trouble Shooting

If the LC-50 is not working, perform this simple test: 1) Disconnect all wires except Power and Ground. 2) Re-connect one potentiometer to "CH1". 3) Connect one lamp to "OUT1".

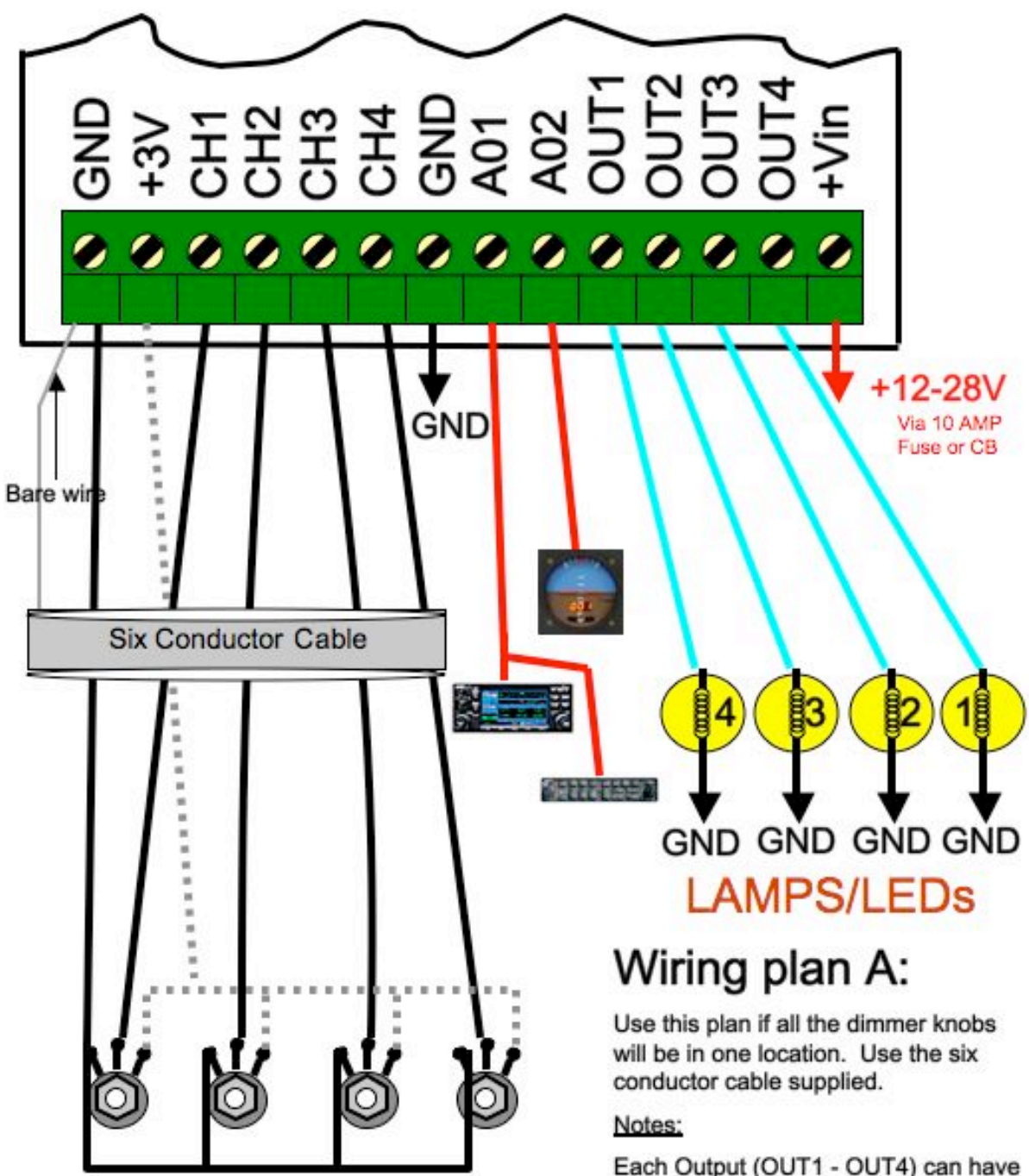

(Shafts facing away into page)

Wiring plan A:

Use this plan if all the dimmer knobs will be in one location. Use the six conductor cable supplied.

Notes:

Each Output (OUT1 - OUT4) can have any number of bulbs/LEDs with a maximum current draw of 1.5 Amps per Output Channel.

Do not use analog outputs (A01, A02) to dim bulbs or LEDs.

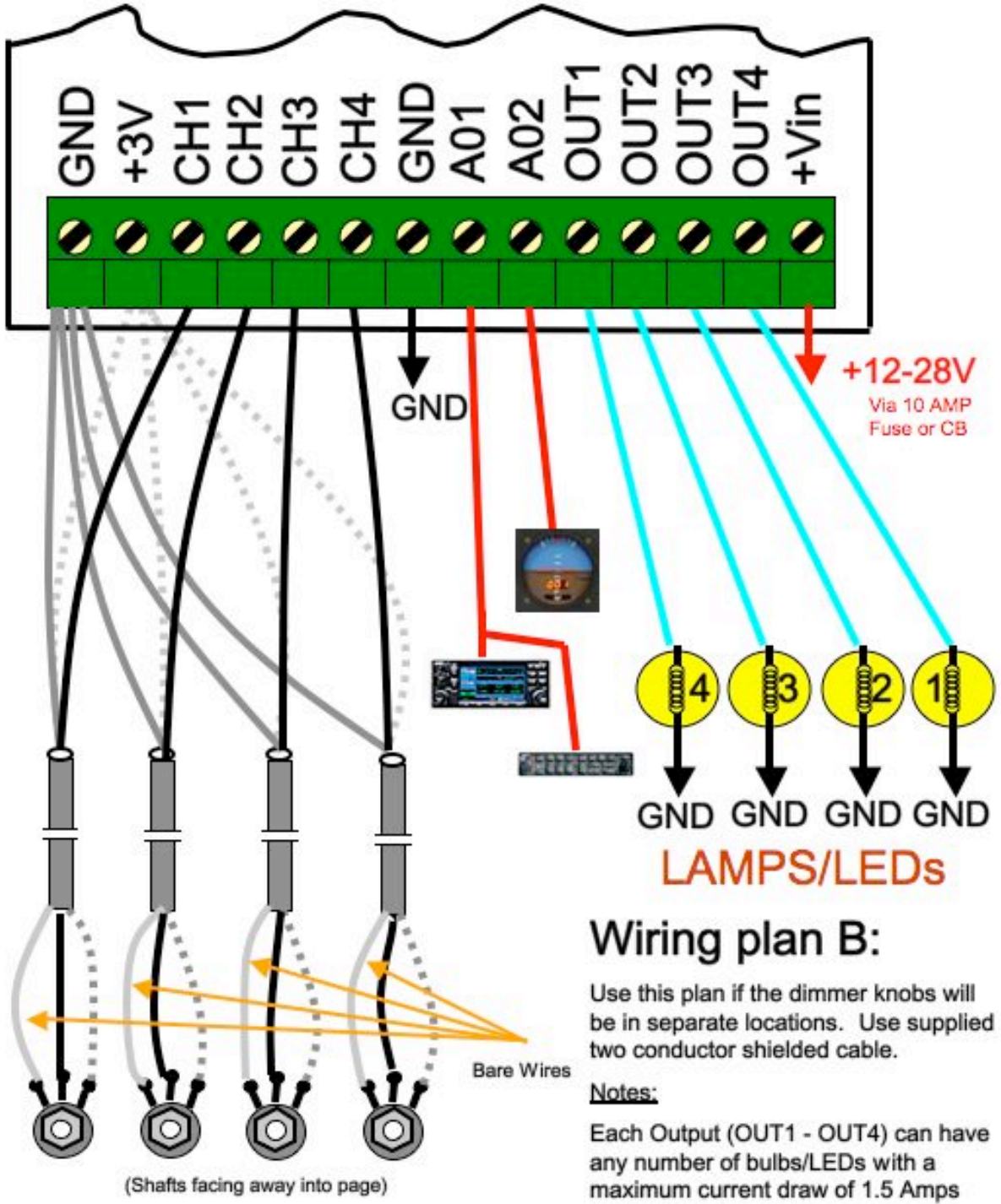

Wiring plan B:

Use this plan if the dimmer knobs will be in separate locations. Use supplied two conductor shielded cable.

Notes:

Each Output (OUT1 - OUT4) can have any number of bulbs/LEDs with a maximum current draw of 1.5 Amps per Output Channel.

Do not use analog outputs (A01, A02) to dim bulbs or LEDs.

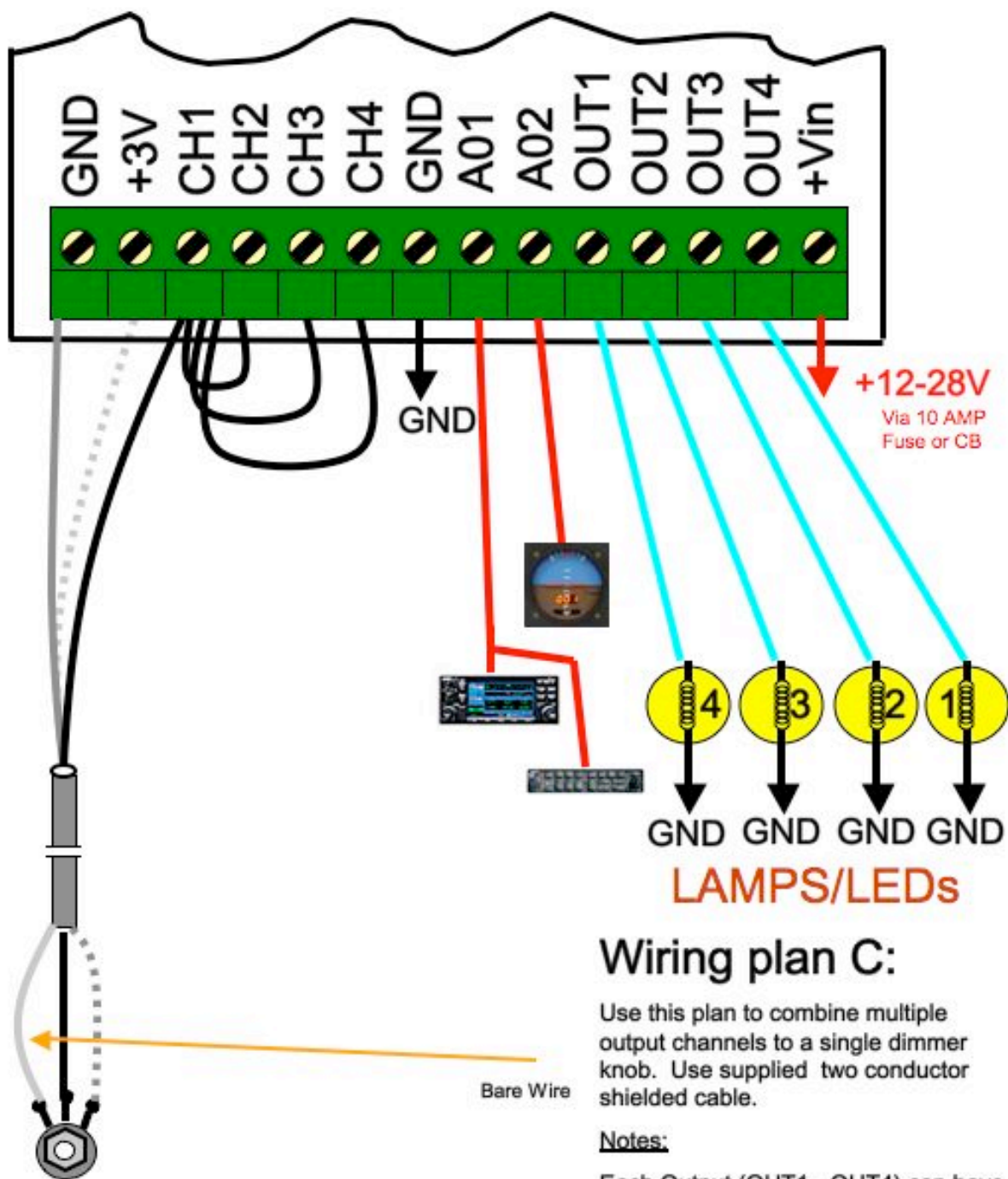

Wiring plan C:

Use this plan to combine multiple output channels to a single dimmer knob. Use supplied two conductor shielded cable.

Notes:

Each Output (OUT1 - OUT4) can have any number of bulbs/LEDs with a maximum current draw of 1.5 Amps per Output Channel.

Do not use analog outputs (A01, A02) to dim bulbs or LEDs.

Rev 6/29/08

TYPICAL INSTALLATION

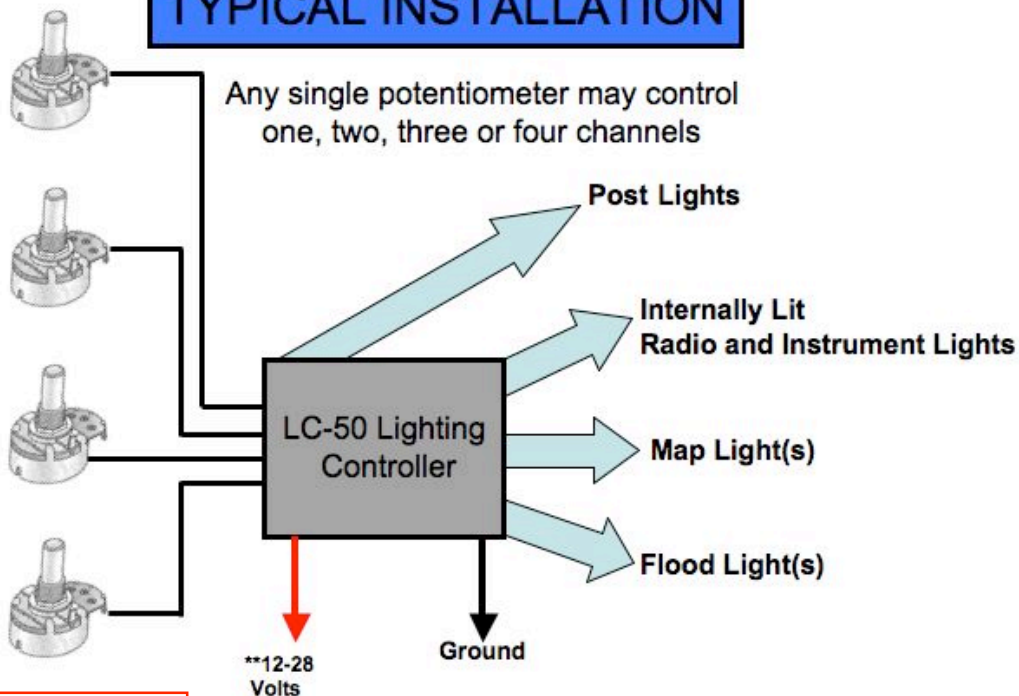

** We suggest powering the LC-50 by connecting it to your Navigation Light switch.



Need Help?

support@fdatasystems.com

or call (831) 325-3131

Suggested Sources for Knobs

Radio Shack

Knob Part Numbers – 274-415, 274-403

Mouser Electronics: 1-800-346-6873 or www.mouser.com

Knob Part Numbers – 506-KB500B1/4, 506-KN500B1/4, 400-ME52, 400-CE15, 450-2040, 450-2050, 450-2060, 450-2070, 450-2023, 450-2034,

See catalog and website for many more....

From LC-50 OUT

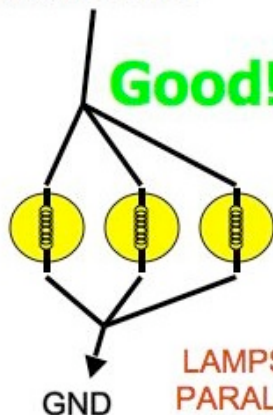

From LC-50 OUT

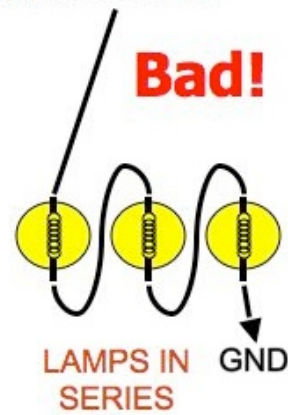

Figure C

Devices Requiring Analog Outputs "A01" or "A02":

- Garmin 400/500 series Radios
- Garmin GTX 327/330 Transponders
- Garmin GMA 347 Audio Panel
- Garmin Displays G900X, G950, G1000 etc...
- Tru-Trak ADI Pilot
- Tru-Trak Pictorial Pilot
- Newer PS Engineering Audio Panels

If your device is not on this list, try using "OUT1 – OUT4".

Specifications

Input Voltage: 12 to 28 Volts DC
 Max PWM Output Current: 1.5 Amps Per Channel
 Max Analog Output Current: 270mA @ 14 Volts, 135mA @ 28 Volts
 Width 3.19", Length 4.09", Height .55", Weight 3.4 oz.