

AFP-30/35 Installation/Operation Manual Addendum

Power

Be sure the unit is not connected to a circuit that is powered when the engine is started or stopped or the alternator is turned on or off. This means not directly powered by the "Master Switch" but rather on the "Avionics Master" or a separate power switch. Failure to do this could damage the unit requiring return to the factory for repair.

Attaching the Sliding Lock Plate

Be sure to use the special #4-40 screws provided as shown below. These are the screws with the stand-off just below screw head to allow the plate to slide.

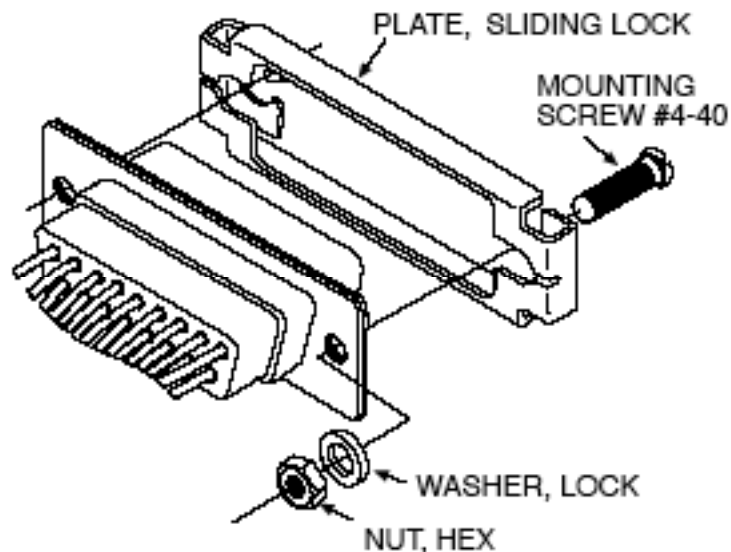

Note: The connector cover is not shown in the above diagram.

Additional setup pages

These pages are only present on software versions 6.7 and later.

Maximum RPM – Leave at 2700 unless you are using the "Standard Engine Profile" in the engine list. If your engine is specifically listed and the max RPM is not 2700 it should still be set to 2700. This setting allows users this allow users of engines not specifically listed to get an accurate percent horsepower reading while using the "Standard Engine Profile".

Pulse Count – This setting allows for a correct tachometer reading for various ignition systems and engine configurations. Set to: 60 divided by the number of ignition pulses per revolution. For example, it should be 30 for four cylinder engines and 20 for six cylinder engines.